



SKD-103-M

POWER OF DIVERSITY

MID-certified three-phase energy meter

The SKD-103-M energy meter provides a detailed overview of energy consumption within a building. Ideal for facility managers or administrators who are responsible for a building and would like to see how the total energy consumption is divided up

With its MID B+D certification, the SKD-103-M is suitable for settlement purposes. This energy meter is suitable for use in single-phase networks, has two pulse outputs, one communication port and sealable cover terminals and can be connected directly (100A)

“The SKD-103-M provides a detailed overview of the energy consumption of each individual consumer group in a building.”

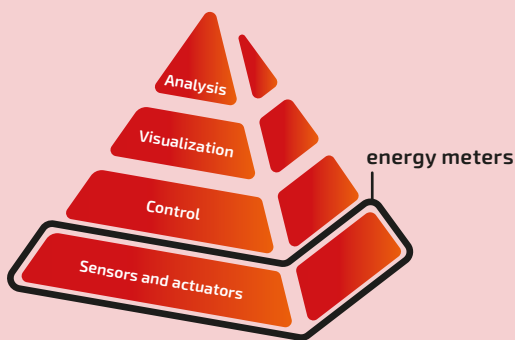

Tip from our product manager: Energy meters as part of a total solution for energy management and building automation. “By using current transformers, energy meters, an energy monitoring tool and visualization and control tools, you can measure, monitor and guarantee the quality of a system.”



We energize the best solutions

+31 (0) 180 330 522



Specification

Specifications	
Certification	MID B+D, CE, RoHS
Connection	Directly in three-phase networks
Measuring voltage	3x 230V L-N or 400V L-L, max 230V +20%
Frequency	50Hz or 60Hz, 80% to 120% of nominal
Direct current	100A, max peak 30 x Inom @ 10ms
Accuracy class	Class 0.5 (active energy)
Degree of protection	IP51 indoors
Insulation	AC: 4kV @ 1 minute, DC: 6kV @ 1.2μs
Pulse outputs	Output 1: configurable, output 2: 400 pulses per kWh
Type of pulse outputs	Passive
Pulse duration	60ms, 100ms (standard), 200ms
Communication port (optional)	Modbus
Load	≤ 2W / 10VA
Montage	DIN-rail (35mm)
Dimensions	94.5mm x 72mm x 65mm, 4 modules wide (72mm)
Screen	LCD with backlight
Maximum reading	9999999.9 kWh, 9999999.9 kVARh
Humidity	≤ 90% in operation, ≤ 95% in storage
Temperature	-25°C to +55°C in operation, -40°C to +70°C in storage, 23°C ±2°C specification
Standards	EN50470-1/3, IEC 62053-21, EN 55022, IEC 61000-4-3
Installation category	Class III
Environment	M1 Mechanical, E2 Electromagnetic
Pollution degree	2
Electrostatic discharges	8kV contact, 15kV air distance

Parameters
Voltage L/L
Voltage THD
Frequency
Current
Zero-current (calculated)
Maximum current
Current THD
kW
kVAr
Maximum consumed kW
Power Factor (Cosine Phi)
Import kWh
Export kWh
Import kVARh
Export kVARh
Export kVARh

Accuracy	
Voltage (V)	0.5% of maximum range
Current (A)	0.5% of nominal
Frequency (Hz)	0.2% of average frequency
Power Factor (Cosinus Phi)	1% of unit (0.01)
Active power (W)	+/- 1% of maximum range
Reactive power (VAR)	+/- 1% of maximum range
Apparent power (VA)	+/- 1% of maximum range
Active energy (Wh)	Class 1 IEC 62053-21, Class B EN 50470-3
Reactive energy (VARh)	Class 2, ±1% of maximum range



SKD-103-M

+31 (0) 180 330 522

Communication port

Bus type	RS485
Protocol	Modbus RTU
Address range	1-247
Baud rate	2400, 4800, 9600, 19200, 38400bps
Parity	Even, odd, none
Data bits	8
Stop bits	1
Maximum bus load	64 pcs
Communication distance	1000M

Connection diagrams & dimensions

1 phase two wires

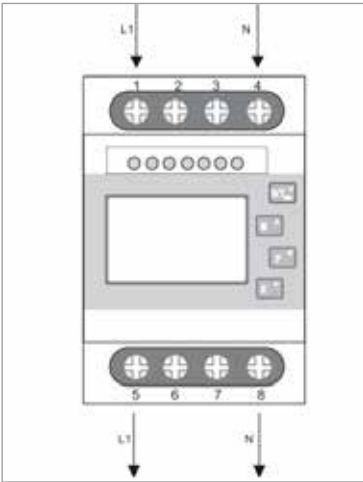

2 phases three wires

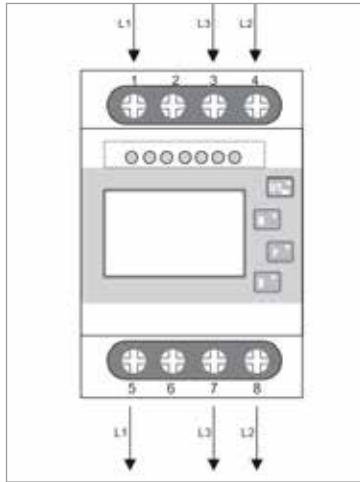

3 phases four wires

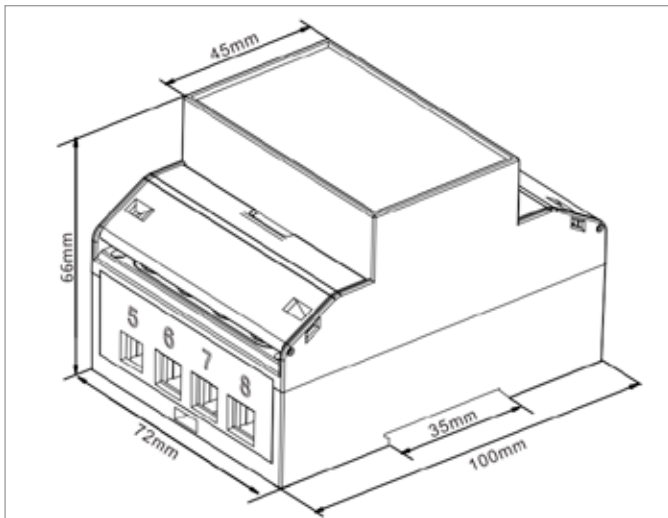
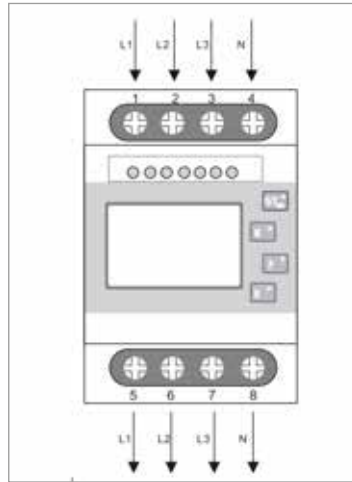

"Energy meters are thanks to the import and export function not only suitable for measuring the energy consumption but also Does the property you facilitate or manage have solar panels? Then an energy meter is the perfect tool to measure the yield of solar panels."

Ordering information

Type	direct current	communication	certificate number	article number
SKD-103-M	100A	2x pulse, 1x Modbus RTU RS485	0120/SGS0240	185-05555-210



SKD-103-M

Controlin

Glasblazerstraat 1-3
2984 BL Ridderkerk
+31 (0) 180 330 522
sales@controlin.com
www.controlin.com